

© DEN HARTOG INDUSTRIES, INC.

Copyright. All information furnished within this document, electronic file or design correspondence is the property of Den Hartog Industries, Inc. and shall not be used, disclosed to others or copied without the expressed written consent of Den Hartog Industries, Inc.

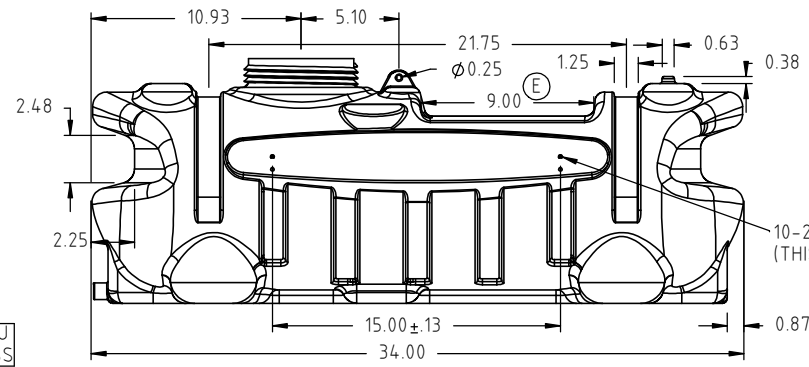
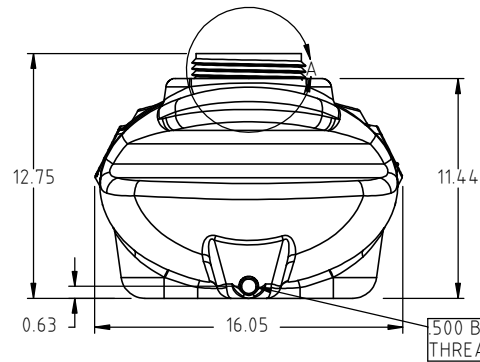

10-24 UNC THREADED BRASS INSERTS X 2 (THIS SIDE ONLY) DHI P.N. 19001

EXCEPT AS NOTED TOLERANCES ARE ± 2% OF DIMENSION NOTED

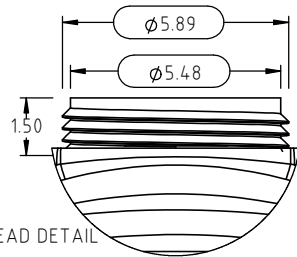

DETAIL A SCALE 1:5
5" BUTTRESS THREAD DETAIL

.75-11.5 NHR HOSE COUPLING THREADS X .75 LONG

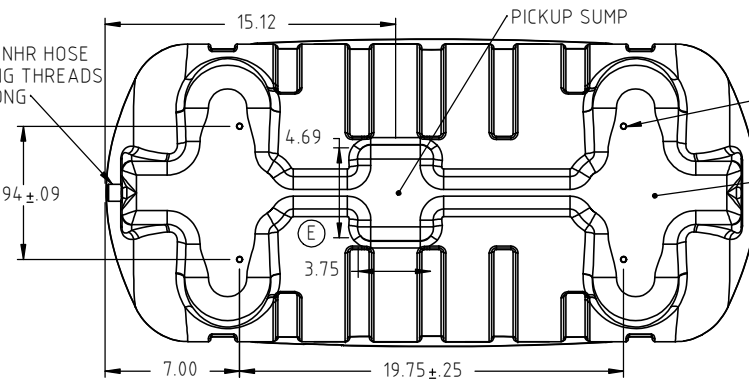

313-18 UNC THREADED NYLON INSERTS X 4 DHI P.N. 19382

TANK BOTTOM SURFACE TO BE FLAT WITHIN .25 T.I.R.

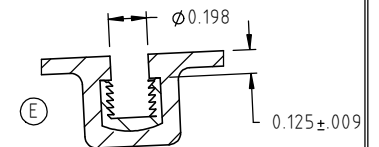

SECTION A-A SCALE 1:1
ALL 10-24 INSERTS

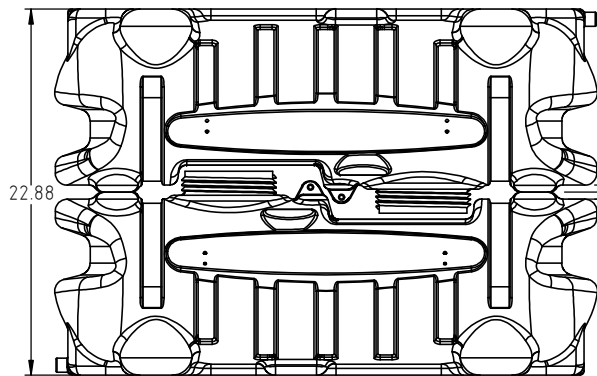

STACKED HEIGHT

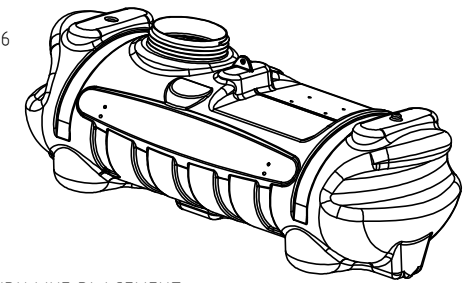
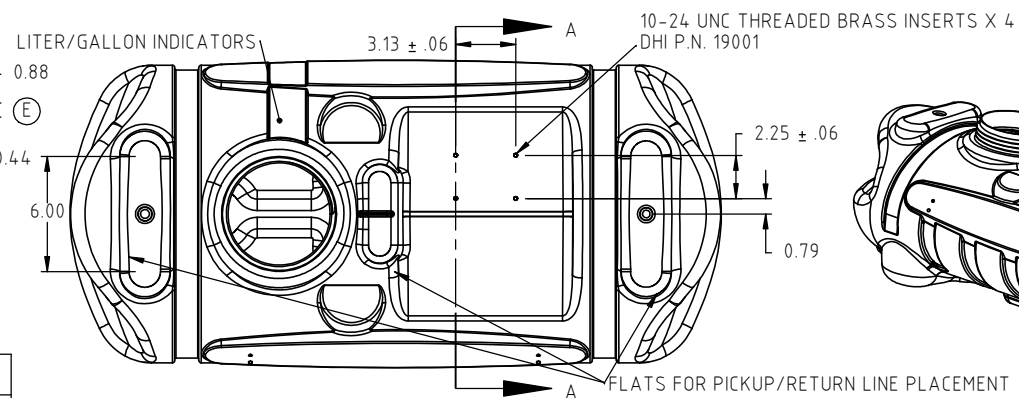

E	INSERT DETAIL ADDED, DIMENSIONS DRAWING TEMPLATE UPDATED	ADH 4/23/13	2605
D	WEIGHT WAS 8 LB.	12/12/05	
C	19000 INSERT CHANGED TO 19382	6/15/05	
B	TOLERANCES CHANGED	8/22/02	
A	TOLERANCES CHANGED	6/20/02	
REV	DESCRIPTION	BY / DATE	CCN

DRAWN / DATE	MATERIAL
REH 11/6/00	MDPE
APPRD. / DATE	
REH 11/6/00	

ALL DIMENSIONS ARE IN DECIMAL INCHES TOLERANCES UNLESS OTHERWISE SPECIFIED
 POLYETHYLENE METAL DECIMAL ± .125" FRACTION ± 1/4" ANGLE ± 1°
 ±1% @ 68°F

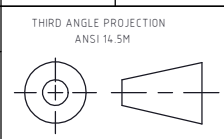

SHOT WEIGHT:	7.5 LBS
SHIPPING WEIGHT:	8.0 LBS
FINISH:	

NOTES:
1) MIN. WALL .080



Den Hartog

INDUSTRIES, INC.

Ace Roto-Mold Injection Molding Blow Molding Sowjoy

4010 HOSPERS DRIVE S. BOX 425, HOSPERS, IOWA 51238-0425

DESCRIPTION	15 GAL. SPOT SPRAYER TANK (BLOW MOLDED)	
SCALE	N.S.	PART NO. SB00015