

A REFERENCE PUBLICATION 10039 FOR SEPTIC TANKS OR PUBLICATION 10149 FOR CISTERN TANKS FOR SPECIFIC INSTALLATION GUIDELINES.

© DEN HARTOG INDUSTRIES, INC.  
 Copyright: All information furnished within this document, electronic file or design correspondence is the property of Den Hartog Industries, Inc. and shall not be used, disclosed to others or copied without the expressed written consent of Den Hartog Industries, Inc.

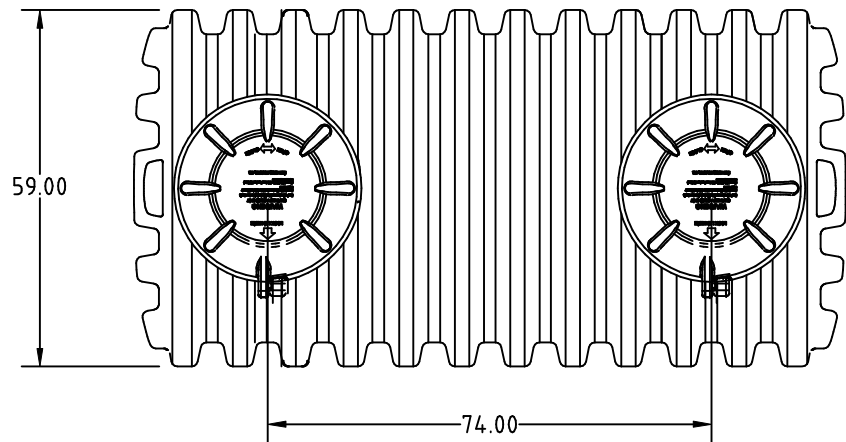

Typical Engraving

Ace Roto Mold  
 A Division of  
 Den Hartog Industries, Inc.

- TANK CAPACITY \_\_\_\_\_ 1250 Gallons
- DATE OF MANUFACTURE \_\_\_\_\_ Month / Year molded
- DATE OF ASSEMBLY \_\_\_\_\_ Month / Year assembled
- SERIAL NUMBER \_\_\_\_\_ Sequential serial number
- STATE / LOCATION \_\_\_\_\_ State assembled for (if applicable)

Max. depth engraving here  
 MAX. BURIAL DEPTH TO TOP OF TANK - 3 FT.

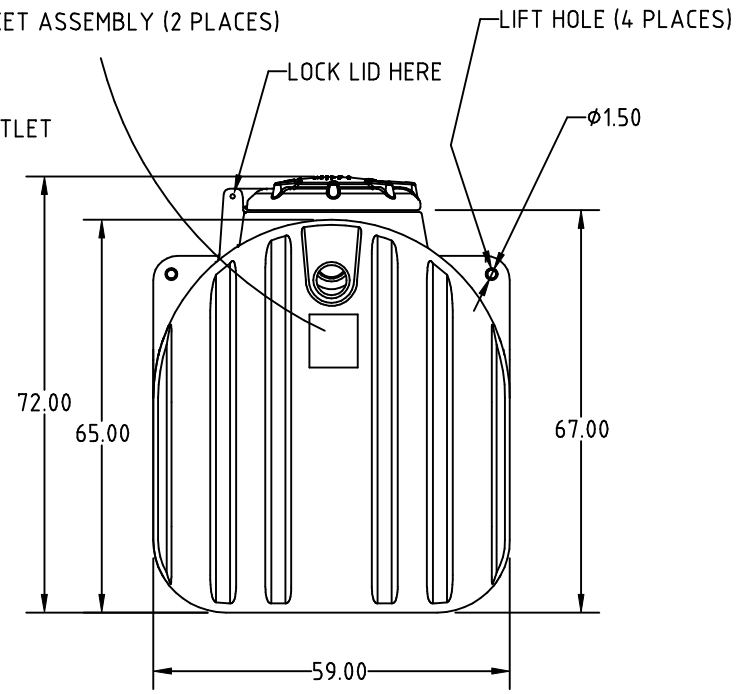
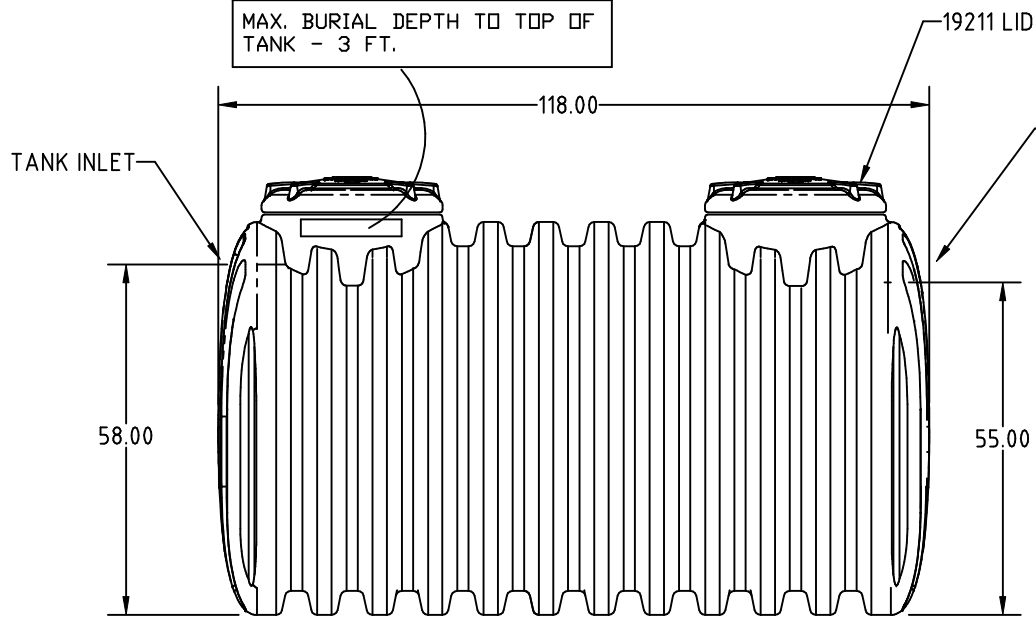

A	ADDED PUBLICATION REF	9/30/05	NVE	APPRD. / DATE	REH / 3/15/04
REV	DESCRIPTION	DATE	APPRD		
ALL DIMENSIONS ARE IN DECIMAL INCHES TOLERANCES UNLESS OTHERWISE SPECIFIED $\pm$ 1% @ 68° F					

DRAWN / DATE	REH / 3/15/04
APPRD. / DATE	REH / 3/15/04
THIRD ANGLE PROJECTION ANSI 14.5M	

MATERIAL  
 EXXON HD8660 HDPE OR EQUIVALENT  
 REFERENCE MATERIAL DATA SHEET  
 FOR SPECIFIC PROPERTIES.

NOTES:  
 1. MIN. WALL @ .250  
 2. YELLOW COLOR  
 3. SHOT WEIGHT 412 LBS.

<p>Ace Roto-Mold                  A DIVISION OF DEN HARTOG INDUSTRIES, INC.</p>	
CLIENT / DESCRIPTION 1250 GAL. SINGLE COMPARTMENT SEPTIC TANK	
SCALE N.S.	PART NO. AST-1250-1