

PARTS LISTING: SP-3220 (2" SELF-PRIMING)

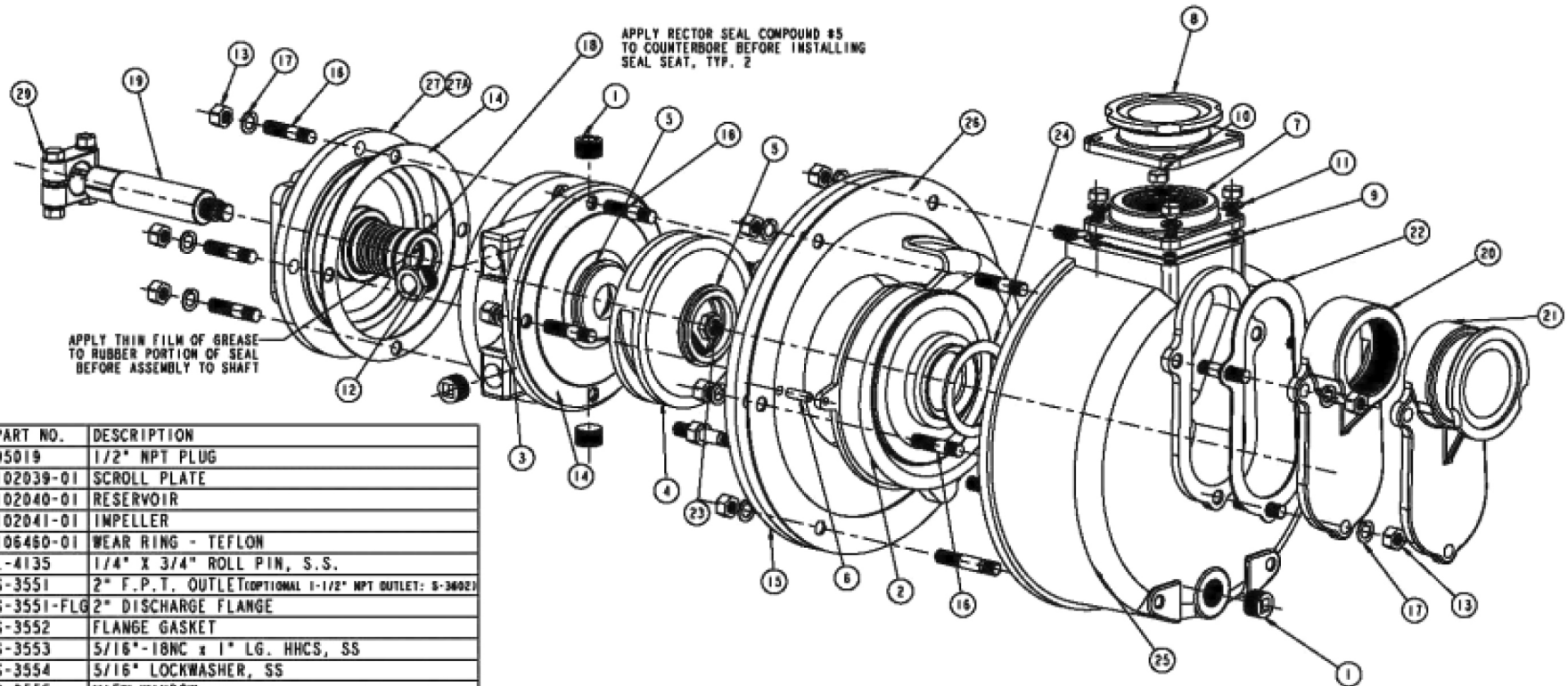

ITEM	QTY	PART NO.	DESCRIPTION
1	4	95019	1/2" NPT PLUG
2	1	102039-01	SCROLL PLATE
3	1	102040-01	RESERVOIR
4	1	102041-01	IMPELLER
5	2	106460-01	WEAR RING - TEFLON
6	2	L-4135	1/4" X 3/4" ROLL PIN, S.S.
7	1	S-3551	2" F.P.T. OUTLET (OPTIONAL 1-1/2" NPT OUTLET: S-3602)
8	1	S-3551-FLG	2" DISCHARGE FLANGE
9	1	S-3552	FLANGE GASKET
10	4	S-3553	5/16" - 18NC x 1" LG. HHCS, SS
11	4	S-3554	5/16" LOCKWASHER, SS
12	1	S-3555	VIEW WINDOW
13	17	S-3557	3/8" NUT S.S.
14	2	S-3558	SEAL GASKET
15	1	S-3559	HOUSING COVER
16	15	S-3561	3/8" x 1-5/8" STUD, S.S.
17	17	S-3562	3/8" SPLIT LW S.S.
18	1	S-3565-V	MECH. DOUBLE SEAL (OPTIONAL CARTRIDGE SEAL: S-3565-VC)
19	1	S-3568	IMPELLER SHAFT
20	1	S-3569	2" F.P.T. SUCTION FLANGE
21	1	S-3569-FLG	2" SUCTION FLANGE
22	1	S-3570	SUCTION FLANGE GASKET
23	1	S-3572	IMPELLER NUT
24	1	S-3577	GASKET
25	1	S-3580	HOUSING
26	1	S-3581	HOUSING GASKET
27	1	S-3556	ADAPTER - GAS ENGINE & PEDESTAL
28	2	S-3597	3/8" x 2" STUD, S.S.
29	1	S-3607S	2" S.S. CLAMP ASSEMBLY
29A	-	S-3609	ADAPTER - ELECTRIC MOTOR

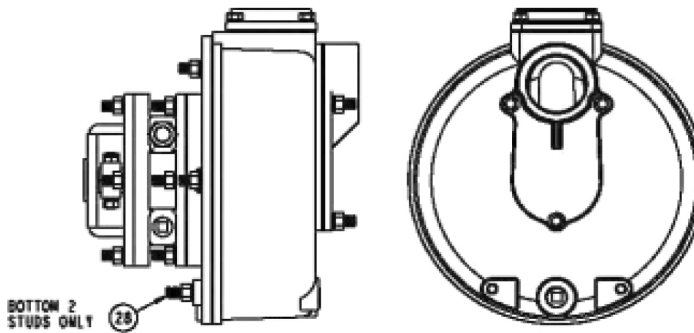

APPLY COPPER BASED ANTI-SEIZE COMPOUND TO THREADS TYP. ALL PLUGS

GASKET AND SEAL KIT: 103276